

## KEELOQ<sup>®</sup> Code Hopping Encoder

### FEATURES

#### Security

- Programmable 28-bit serial number
- Programmable 64-bit encryption key
- Each transmission is unique
- 66-bit transmission code length
- 32-bit hopping code
- 34-bit fixed code (28-bit serial number, 4-bit button code, 2-bit status)
- Encryption keys are read protected

#### Operating

- 2.0—6.3V operation
- Four button inputs
- No additional circuitry required
- 15 functions available
- Selectable baud rate
- Automatic code word completion
- Battery low signal transmitted to receiver
- Non-volatile synchronization data

#### Other

- Easy to use programming interface
- On-chip EEPROM
- On-chip oscillator and timing components
- Button inputs have internal pulldown resistors
- Current limiting on LED output
- Minimum component count
- Synchronous transmission mode

#### Typical Applications

The HCS300 is ideal for Remote Keyless Entry (RKE) applications. These applications include:

- Automotive RKE systems
- Automotive alarm systems
- Automotive immobilizers
- Gate and garage door openers
- Identity tokens
- Burglar alarm systems

### DESCRIPTION

The HCS300 from Microchip Technology Inc., is a code hopping encoder designed for secure Remote Keyless Entry (RKE) systems. The HCS300 utilizes the <sup>®</sup> code hopping technology, which incorporates high security, a small package outline and low cost to make this device a perfect solution for unidirectional remote keyless entry systems and access control systems.

### PACKAGE TYPES

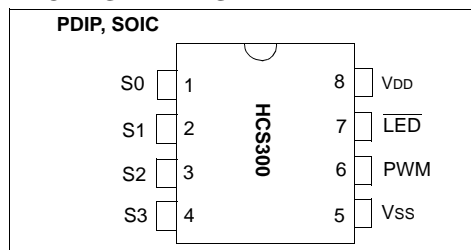

### HCS300 BLOCK DIAGRAM

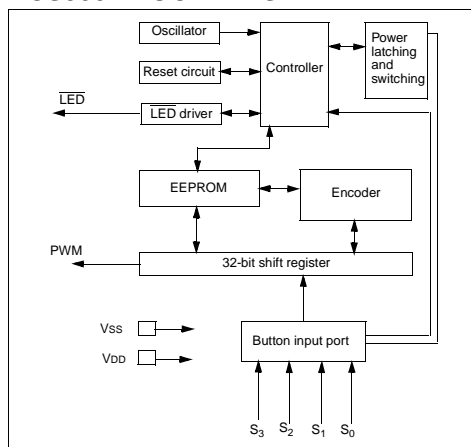

KEELOQ is a registered trademark of Microchip Technology, Inc.

Microchip's Secure Data Products are covered by some or all of the following patents:

Code hopping encoder patents issued in Europe, U.S.A., and R.S.A. — U.S.A.: 5,517,187; Europe: 0459781; R.S.A.: ZA93/4726

The HCS300 combines a 32-bit hopping code generated by a non-linear encryption algorithm, with a 28-bit serial number and six status bits to create a 66-bit transmission stream. The length of the transmission eliminates the threat of code scanning and the code hopping mechanism makes each transmission unique, thus rendering code capture and resend (code grabbing) schemes useless.

The encryption key, serial number, and configuration data are stored in EEPROM, which is not accessible via any external connection. This makes the HCS300 a very secure unit. The HCS300 provides an easy to use serial interface for programming the necessary security keys, system parameters, and configuration data.

The encryption keys and code combinations are programmable but read-protected. The keys can only be verified after an automatic erase and programming operation. This protects against attempts to gain access to keys and manipulate synchronization values.

The HCS300 operates over a wide voltage range of 2.0V to 6.3V and has four button inputs in an 8-pin configuration. This allows the system designer the freedom to utilize up to 15 functions. The only components required for device operation are the buttons and RF circuitry, allowing for a very low system cost.

## 1.0 SYSTEM OVERVIEW

### Key Terms

- **Manufacturer's code** - a 64-bit word, unique to each manufacturer, used to produce a unique encryption key in each transmitter (encoder).
- **Encryption Key** - a unique 64-bit key generated and programmed into the encoder during the manufacturing process. The encryption key controls the encryption algorithm and is stored in EEPROM on the encoder device.

### 1.1 Learn

The HCS product family facilitates several learn strategies to be implemented on the decoder. The following are examples of what can be done. It must be pointed out that there exists some third-party patents on learning strategies and implementation.

#### 1.1.1 NORMAL LEARN

The receiver uses the same information that is transmitted during normal operation to derive the transmitter's secret key, decrypt the discrimination value and the synchronization counter.

#### 1.1.2 SECURE LEARN\*

The transmitter is activated through a special button combination to transmit a stored 48-bit value (random seed) that can be used for key generation or be part of the key. Transmission of the random seed can be disabled after learning is completed.

The HCS300 is a code hopping encoder device that is designed specifically for keyless entry systems, primarily for vehicles and home garage door openers. It is meant to be a cost-effective, yet secure solution to such systems. The encoder portion of a keyless entry system is meant to be held by the user and operated to gain access to a vehicle or restricted area. The HCS300 requires very few external components (Figure 2-1).

Most keyless entry systems transmit the same code from a transmitter every time a button is pushed. The relative number of code combinations for a low end system is also a relatively small number. These shortcomings provide the means for a sophisticated thief to create a device that 'grabs' a transmission and re-transmits it later or a device that scans all possible combinations until the correct one is found.

The HCS300 employs the code hopping technology and an encryption algorithm to achieve a high level of security. Code hopping is a method by which the code transmitted from the transmitter to the receiver is different every time a button is pushed. This method, coupled with a transmission length of 66 bits, virtually eliminates the use of code 'grabbing' or code 'scanning'.

As indicated in the block diagram on page one, the HCS300 has a small EEPROM array which must be loaded with several parameters before use. The most important of these values are:

- A 28-bit serial number which is meant to be unique for every encoder.
- An encryption key that is generated at the time of production.
- A 16-bit synchronization value.

The serial number for each transmitter is programmed by the manufacturer at the time of production. The generation of the encryption key is done using a key generation algorithm (Figure 1-1). Typically, inputs to the key generation algorithm are the serial number of the transmitter and a 64-bit manufacturer's code. The manufacturer's code is chosen by the system manufacturer and must be carefully controlled. The manufacturer's code is a pivotal part of the overall system security.

**FIGURE 1-1: CREATION AND STORAGE OF ENCRYPTION KEY DURING PRODUCTION**

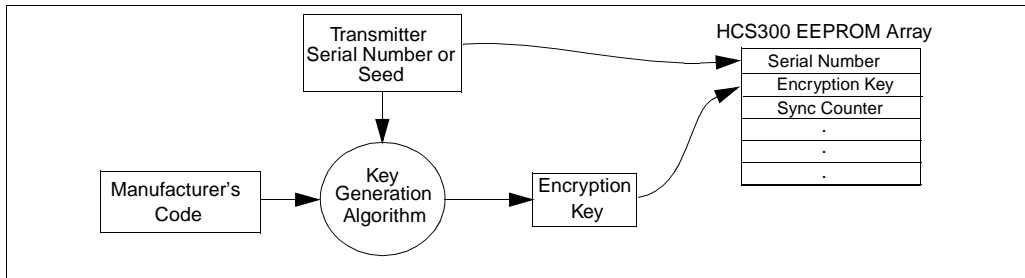

The 16-bit synchronization value is the basis for the transmitted code changing for each transmission, and is updated each time a button is pressed. Because of the complexity of the code hopping encryption algorithm, a change in one bit of the synchronization value will result in a large change in the actual transmitted code. There is a relationship (Figure 1-2) between the key values in EEPROM and how they are used in the encoder. Once the encoder detects that a button has been pressed, the encoder reads the button and updates the synchronization counter. The synchronization value is then combined with the encryption key in the encryption algorithm and the output is 32 bits of encrypted information. This data will change with every button press, hence, it is referred to as the hopping portion of the code word. The 32-bit hopping code is combined with the button information and the serial number to form the code word transmitted to the receiver. The code word format is explained in detail in Section 4.2.

Any type of controller may be used as a receiver, but it is typically a microcontroller with compatible firmware that allows the receiver to operate in conjunction with a transmitter, based on the HCS300. Section 7.0 provides more detail on integrating the HCS300 into a total system.

Before a transmitter can be used with a particular receiver, the transmitter must be 'learned' by the receiver. Upon learning a transmitter, information is stored by the receiver so that it may track the transmitter, including the serial number of the transmitter, the current synchronization value for that transmitter and the same encryption key that is used on the transmitter. If a receiver receives a message of valid format, the serial number is checked and, if it is from a learned transmitter, the message is decrypted and the decrypted synchronization counter is checked against what is stored. If the synchronization value is verified, then the button status is checked to see what operation is needed. Figure 1-3 shows the relationship between some of the values stored by the receiver and the values received from the transmitter.

**FIGURE 1-2: BASIC OPERATION OF TRANSMITTER (ENCODER)**

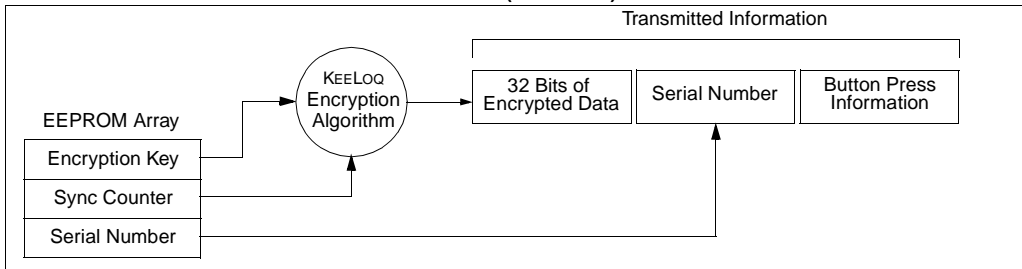

**FIGURE 1-3: BASIC OPERATION OF RECEIVER (DECODER)**

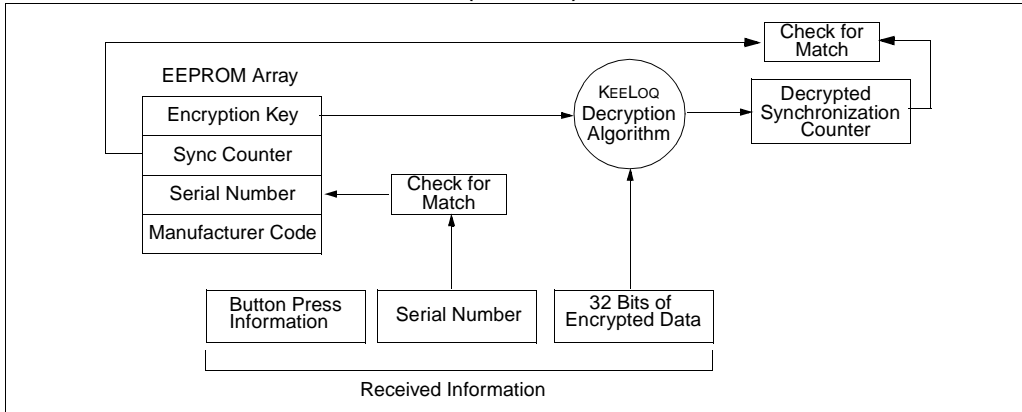

## 2.0 DEVICE OPERATION

As shown in the typical application circuits (Figure 2-1), the HCS300 is a simple device to use. It requires only the addition of buttons and RF circuitry for use as the transmitter in your security application. A description of each pin is described in Table 2-1.

**FIGURE 2-1: TYPICAL CIRCUITS**

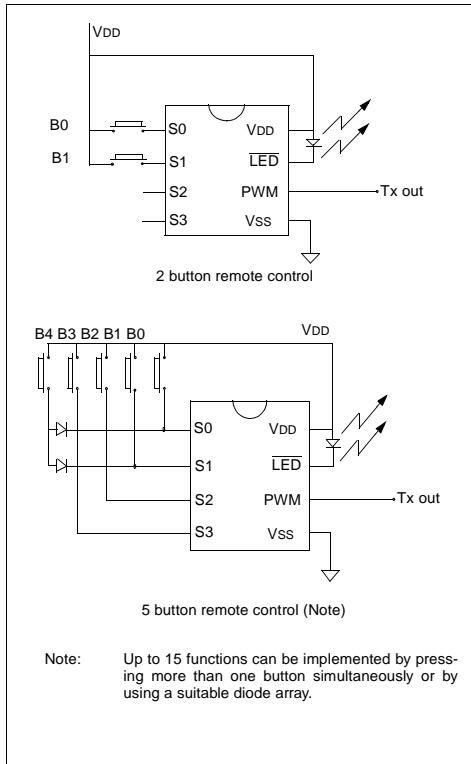

**TABLE 2-1: PIN DESCRIPTIONS**

Name	Pin Number	Description
S0	1	Switch input 0
S1	2	Switch input 1
S2	3	Switch input 2/Can also be clock pin when in programming mode
S3	4	Switch input 3/Clock pin when in programming mode
Vss	5	Ground reference connection
PWM	6	Pulse width modulation (PWM) output pin/Data pin for programming mode
LED	7	Cathode connection for directly driving LED during transmission
VDD	8	Positive supply voltage connection

The high security level of the HCS300 is based on the patented technology. A block cipher type of encryption algorithm based on a block length of 32 bits and a key length of 64 bits is used. The algorithm obscures the information in such a way that even if the transmission information (before coding) differs by only one bit from the information in the previous transmission, the next coded transmission will be totally different. Statistically, if only one bit in the 32-bit string of information changes, approximately 50 percent of the coded transmission will change. The HCS300 will wake up upon detecting a switch closure and then delay approximately 10 ms for switch debounce (Figure 2-2). The synchronized information, fixed information, and switch information will be encrypted to form the hopping code. The encrypted or hopping code portion of the transmission will change every time a button is pressed, even if the same button is pushed again. Keeping a button pressed for a long time will result in the same code word being transmitted, until the button is released or timeout occurs. A code that has been transmitted will not occur again for more than 64K transmissions. This will provide more than 18 years of typical use before a code is repeated, based on 10 operations per day. Overflow information programmed into the encoder can be used by the decoder to extend the number of unique transmissions to more than 192K.

If in the transmit process it is detected that a new button(s) has been pressed, a reset will immediately be forced and the code word will not be completed. Please note that buttons removed will not have any effect on the code word unless no buttons remain pressed in which case the current code word will be completed and the power down will occur.

**FIGURE 2-2: ENCODER OPERATION**

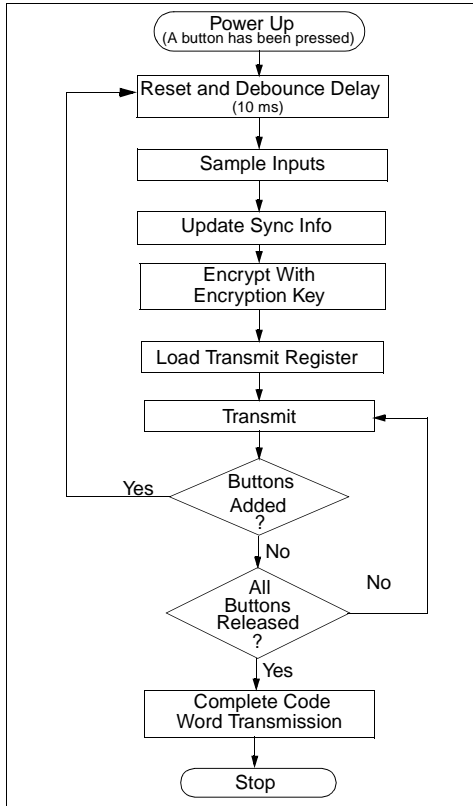

## 3.0 EEPROM MEMORY ORGANIZATION

The HCS300 contains 192 bits (12 x 16-bit words) of EEPROM memory (Table 3-1). This EEPROM array is used to store the encryption key information, synchronization value, etc. Further descriptions of the memory array is given in the following sections.

**TABLE 3-1: EEPROM MEMORY MAP**

WORD ADDRESS	MNEMONIC	DESCRIPTION
0	KEY_0	64-bit encryption key (word 0)
1	KEY_1	64-bit encryption key (word 1)
2	KEY_2	64-bit encryption key (word 2)
3	KEY_3	64-bit encryption key (word 3)
4	SYNC	16-bit synchronization value
5	RESERVED	Set to 0000H
6	SER_0	Device Serial Number (word 0)
7	SER_1(Note)	Device Serial Number (word 1)
8	SEED_0	Seed Value (word 0)
9	SEED_1	Seed Value (word 1)
10	EN_KEY	16-bit Envelope Key
11	CONFIG	Config Word

**Note:** The MSB of the serial number contains a bit used to select the auto shutoff timer.

### 3.1 Key\_0 - Key\_3 (64-Bit Encryption Key)

The 64-bit encryption key is used by the transmitter to create the encrypted message transmitted to the receiver. This key is created and programmed at the time of production using a key generation algorithm. Inputs to the key generation algorithm are the serial number for the particular transmitter being used and a secret manufacturer's code. While the key generation algorithm supplied is the typical method used, a user may elect to create their own method of key generation. This may be done, providing that the decoder is programmed with the same means of creating the key for decryption purposes. If a seed is used, the seed will also form part of the input to the key generation algorithm.

### 3.2 SYNC (Synchronization Counter)

This is the 16-bit synchronization value that is used to create the hopping code for transmission. This value will be changed after every transmission.

### 3.3 SER\_0, SER\_1 (Encoder Serial Number)

SER\_0 and SER\_1 are the lower and upper words of the device serial number, respectively. Although there are 32 bits allocated for the serial number, only the lower order 28 bits are transmitted. The serial number is meant to be unique for every transmitter. The most significant bit of the serial number (Bit 31) is used to turn the auto shutoff timer on or off.

#### 3.3.1 AUTO SHUTOFF TIMER SELECT

The most significant bit of the serial number (Bit 31) is used to turn the Auto shutoff timer on or off. This timer prevents the transmitter from draining the battery should a button get stuck in the on position for a long period of time. The time period is approximately 25 seconds, after which the device will go to the Time-out mode. When in the Time-out mode, the device will stop transmitting, although since some circuits within the device are still active, the current draw within the Shutoff mode will be more than Standby mode. If the most significant bit in the serial number is a one, then the auto shutoff timer is enabled, and a zero in the most significant bit will disable the timer. The length of the timer is not selectable.

### 3.4 SEED\_0, SEED\_1 (Seed Word)

This is the two word (32 bits) seed code that will be transmitted when all four buttons are pressed at the same time. This allows the system designer to implement the secure learn feature or use this fixed code word as part of a different key generation/tracking process or purely as a fixed code transmission.

### 3.5 EN\_Key (Envelope Encryption Key)

Envelope encryption is a selectable option that encrypts the portion of the transmission that contains the transmitter serial number. Selecting this option is done by setting the appropriate bit in the configuration word (Table 3-2). Normally, the serial number is transmitted in the clear (un-encrypted), but for an added level of security, the system designer may elect to implement this option. The envelope encryption key is used to encrypt the serial number portion of the transmission, if the envelope encryption option has been selected. The envelope encryption algorithm is a different algorithm than the key generation or transmit encryption algorithm. The EN\_key is typically a random number and the same for all transmitters in a system.

### 3.6 Configuration Word

The configuration word is a 16-bit word stored in EEPROM array that is used by the device to store information used during the encryption process, as well as the status of option configurations. Further explanations of each of the bits are described in the following sections.

**TABLE 3-2: CONFIGURATION WORD**

Bit Number	Bit Description
0	Discrimination Bit 0
1	Discrimination Bit 1
2	Discrimination Bit 2
3	Discrimination Bit 3
4	Discrimination Bit 4
5	Discrimination Bit 5
6	Discrimination Bit 6
7	Discrimination Bit 7
8	Discrimination Bit 8
9	Discrimination Bit 9
10	Overflow Bit 0 (OVR0)
11	Overflow Bit 1 (OVR1)
12	Low Voltage Trip Point Select
13	Baudrate Select Bit 0 (BSL0)
14	Baudrate Select Bit 1 (BSL1)
15	Envelope Encryption Select (EENC)

#### 3.6.1 DISCRIMINATION VALUE (DISC0 TO DISC9)

The discrimination value can be programmed with any value to serve as a post decryption check on the decoder end. In a typical system, this will be programmed with the 10 least significant bits of the serial number, which will also be stored by the receiver system after a transmitter has been learned. The discrimination bits are part of the information that is to form the encrypted portion of the transmission. After the receiver has decrypted a transmission, the discrimination bits can be checked against the stored value to verify that the decryption process was valid.

#### 3.6.2 OVERFLOW BITS (OVR0 AND OVR1)

The overflow bits are used to extend the number of possible synchronization values. The synchronization counter is 16 bits in length, yielding 65,536 values before the cycle repeats. Under typical use of 10 operations a day, this will provide nearly 18 years of use before a repeated value will be used. Should the system designer conclude that is not adequate, then the overflow bits can be utilized to extend the number of unique values. This can be done by programming OVR0 and OVR1 to 1s at the time of production. The encoder will automatically clear OVR0 the first time that the synchronization value wraps from 0xFFFF to

0x0000 and clear OVR1 the second time the counter wraps. Once cleared, OVR0 and OVR1 cannot be set again, thereby creating a permanent record of the counter overflow. This prevents fast cycling of 64K counter. If the decoder system is programmed to track the overflow bits, then the effective number of unique synchronization values can be extended to 196,608. If programmed to zero, the system will be compatible with the NTQ104/5/6 devices (i.e., no overflow with discrimination bits set to zero).

### 3.6.3 ENVELOPE ENCRYPTION (EENC)

If the EENC bit is set to a 1, the 32-bit fixed code part of the transmission will also be encrypted so that it will appear to be random. The 16-bit envelope key and envelope algorithm will be used for encryption.

### 3.6.4 BAUDRATE SELECT BITS (BSL0, BSL1)

BSL0 and BSL1 select the speed of transmission and the code word blanking. Table 3-3 shows how the bits are used to select the different baud rates and Section 5.2 provides detailed explanation in code word blanking.

**TABLE 3-3: BAUDRATE SELECT**

BSL1	BSL0	Basic Pulse Element	Code Words Transmitted
0	0	400µs	All
0	1	200µs	1 out of 2
1	0	100µs	1 out of 2
1	1	100µs	1 out of 4

### 3.6.5 LOW VOLTAGE TRIP POINT SELECT

The low voltage trip point select bit is used to tell the HCS300 what  $V_{DD}$  level is being used. This information will be used by the device to determine when to send the voltage low signal to the receiver. When this bit is set to a one, the  $V_{DD}$  level is assumed to be operating from a 5 volt or 6 volt  $V_{DD}$  level. If the bit is set low, then the  $V_{DD}$  level is assumed to be 3.0 volts. Refer to Figure 3-1 for voltage trip point. VLOW is tested at 6.3V at -25°C and +85°C and 2.0V at -25°C and +85°C

**FIGURE 3-1: TYPICAL VOLTAGE TRIP POINTS**

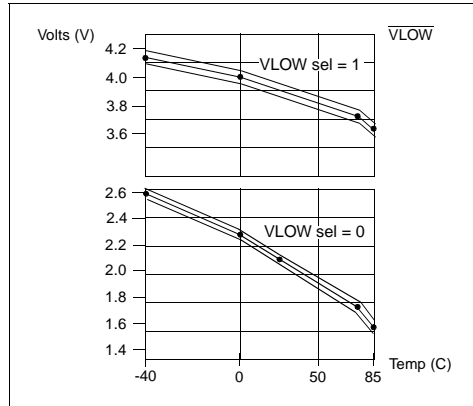

## 4.0 TRANSMITTED WORD

### 4.1 Transmission Format (PWM)

The HCS300 transmission is made up of several parts (Figure 4-1). Each transmission is begun with a preamble and a header, followed by the encrypted and then the fixed data. The actual data is 66 bits which consists of 32 bits of encrypted data and 34 bits of fixed data. Each transmission is followed by a guard period before another transmission can begin. Refer to Table 8-4 for transmission timing requirements. The encrypted portion provides up to four billion changing code combinations and includes the button status bits (based on which buttons were activated) along with the synchronization counter value and some discrimination bits. The fixed portion is comprised of the status bits, the function bits and the 28-bit serial number. The fixed and encrypted sections combined increase the number of combinations to  $7.38 \times 10^{19}$ .

### 4.2 Synchronous Transmission Mode

Synchronous transmission mode can be used to clock the code word out using an external clock.

To enter synchronous transmission mode, the programming mode start-up sequence must be executed as shown in Figure 4-3. If either S1 or S0 is set on the falling edge of S2 (or S3), the device enters synchronous transmission mode. In this mode, it functions as a normal transmitter, with the exception that the timing of the PWM data string is controlled externally and 16 extra bits are transmitted at the end with the code word. The button code will be the S0, S1 value at the falling edge of S2 or S3. The timing of the PWM data string is controlled by supplying a clock on S2 or S3 and should not exceed 20 kHz. The code word is the same as in PWM mode with 16 reserved bits at the end of the word. The reserved bits can be ignored. When in syn-



chronous transmission mode S2 or S3 should not be toggled until all internal processing has been completed as shown in Figure 4-4.

### 4.3 Code Word Organization

The HCS300 transmits a 66-bit code word when a button is pressed. The 66-bit word is constructed from a Fixed Code portion and an Encrypted Code portion (Figure 4-2).

The **Encrypted Data** is generated from four button bits, two overflow counter bits, ten discrimination bits, and the 16-bit synchronization value (Figure 8-4).

The **Fixed Code Data** is made up from two status bits, four button bits, and the 28-bit serial number. The four button bits and the 28-bit serial number may be encrypted with the Envelope Key, if the envelope encryption is enabled by the user.

**FIGURE 4-1: CODE WORD TRANSMISSION FORMAT**

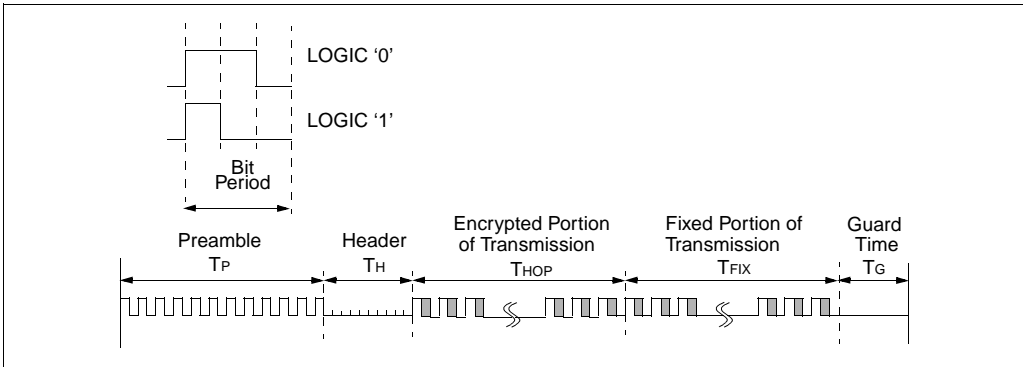

**FIGURE 4-2: CODE WORD ORGANIZATION**

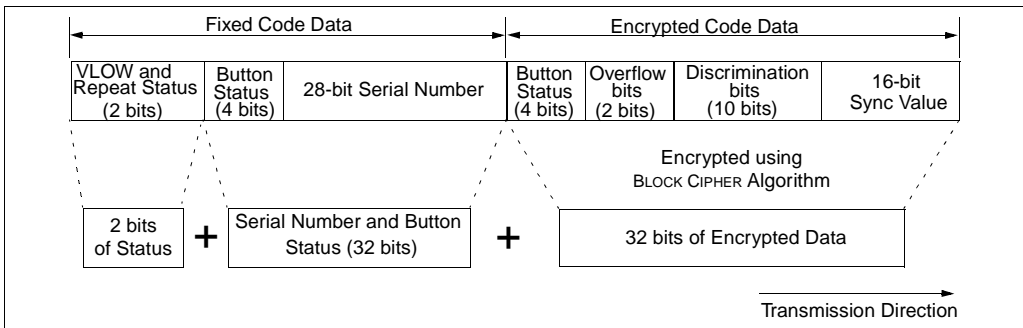

**FIGURE 4-3: SYNCHRONOUS TRANSMISSION MODE**

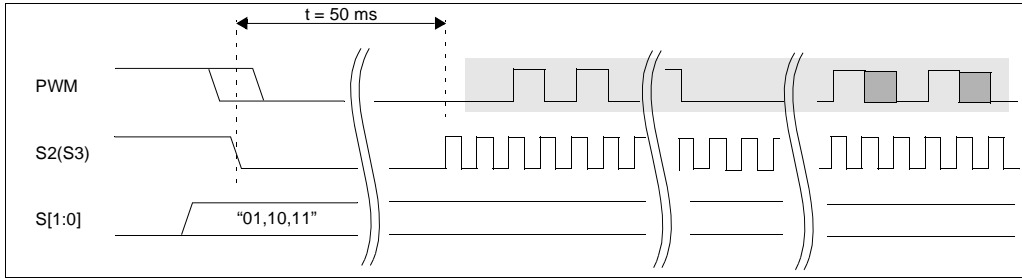

**FIGURE 4-4: TRANSMISSION WORD FORMAT DURING SYNCHRONOUS TRANSMISSION MODE**

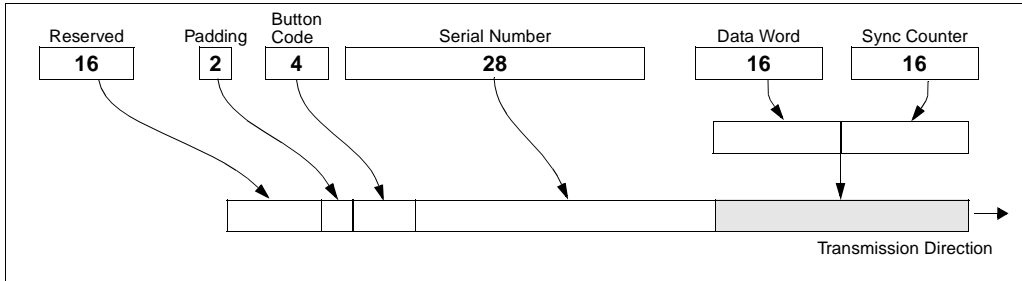

## 5.0 SPECIAL FEATURES

### 5.1 Code Word Completion

Code word completion is an automatic feature that makes sure that the entire code word is transmitted, even if the button is released before the transmission is complete. The HCS300 encoder powers itself up when a button is pushed and powers itself down after the command is finished, if the user has already released the button. If the button is held down beyond the time for one transmission, then multiple transmissions will result. If another button is activated during a transmission, the active transmission will be aborted and the new code will be generated using the new button information.

### 5.2 Blank Alternate Code Word

Federal Communications Commission (FCC) Part 15 rules specify the limits on fundamental power and harmonics that can be transmitted. Power is calculated on the worst case average power transmitted in a 100ms window. It is therefore advantageous to minimize the duty cycle of the transmitted word. This can be achieved by minimizing the duty cycle of the individual bits and by blanking out consecutive words. Blank Alternate Code Word (BACW) is used for reducing the average power of a transmission (Figure 5-1). This is a selectable feature that is determined in conjunction with the baudrate selection bits BSL0 and BSL1. Using the BACW allows the user to transmit a higher amplitude transmission if the transmission length is shorter. The FCC puts

constraints on the average power that can be transmitted by a device, and BACW effectively prevents continuous transmission by only allowing the transmission of every second or every fourth code word. This reduces the average power transmitted and hence, assists in FCC approval of a transmitter device.

### 5.3 Envelope Encryption Option

Envelope Encryption is a user selectable option which is meant to offer a higher level of security for a code hopping system. During a normal transmission with the envelope encryption turned off, the 28-bit serial number is transmitted in the clear (unencrypted). If envelope encryption is selected, then the serial number is also encrypted before transmission. The encryption for the serial number is done using a different algorithm than the transmission algorithm. The envelope encryption scheme is not nearly as complex as the algorithm and, hence, not as secure. When the envelope encryption is used, the serial number must be decrypted using the envelope key and envelope decryption. After the serial number is obtained, the normal decryption method can be used to decrypt the hopping code. All transmitters in a system must use the same envelope key.

### 5.4 Secure Learn

In order to increase the level of security in a system, it is possible for the receiver to implement what is known as a secure learn function. This can be done by utilizing the seed value on the HCS300 which is stored in EEPROM and can only be transmitted when all four

button inputs are pressed at the same time (Table 5-1). Instead of the normal key generation method being used to create the encryption key, this seed value is used and there need not be any mathematical relationship between serial numbers and seeds.

**TABLE 5-1: PIN ACTIVATION TABLE**

	S3	S2	S1	S0	Notes
1	0	0	0	1	1
2	0	0	1	0	1
3	0	0	1	1	1
4	0	1	0	0	1
5	0	1	0	1	1
6	0	1	1	0	1
7	0	1	1	1	1
8	1	0	0	0	1
9	1	0	0	1	1
10	1	0	1	0	1
11	1	0	1	1	1
12	1	1	0	0	1
13	1	1	0	1	1
14	1	1	1	0	1
15	1	1	1	1	2

**Note 1:** Transmit generated 32-bit code hopping word.

**2:** Transmit 32-bit seed value.

## 5.5 Auto-shutoff

The Auto-shutoff function automatically stops the device from transmitting if a button inadvertently gets pressed for a long period of time. This will prevent the device from draining the battery if a button gets pressed while the transmitter is in a pocket or purse. This function can be enabled or disabled and is selected by setting or clearing the Auto-shutoff bit (see Section 3.3.1). Setting this bit high will enable the function (turn Auto-shutoff function on) and setting the bit low will disable the function. Time-out period is approximately 25 seconds.

**FIGURE 5-1: BLANK ALTERNATE CODE WORD (BACW)**

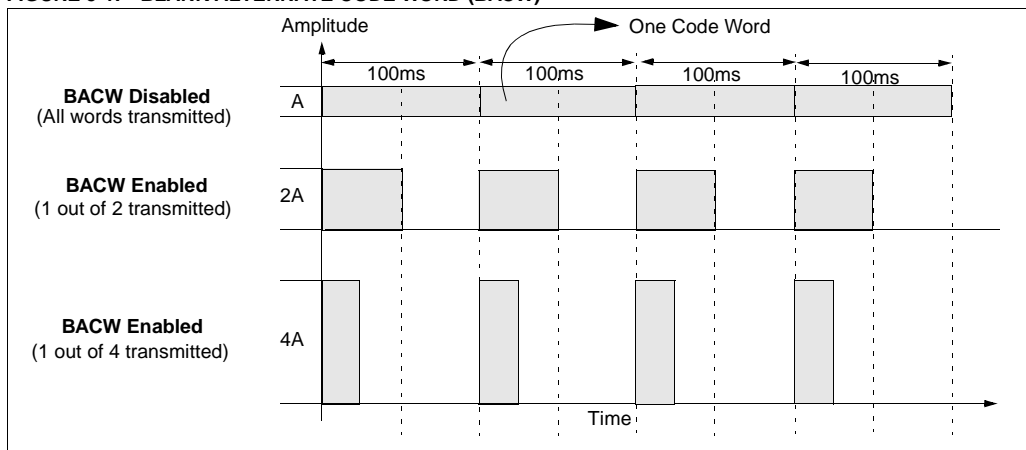

## 5.6 VLOW: Voltage LOW Indicator

The VLOW bit is transmitted with every transmission (Figure 8-4) and will be transmitted as a one if the operating voltage has dropped below the low voltage trip point. The trip point is selectable between two values, based on the battery voltage being used. See Section 3.6.5 for a description of how the low voltage select option is set. This VLOW signal is transmitted so the receiver can give an audible signal to the user that the transmitter battery is low (Section 5.8).

## 5.7 RPT: Repeat Indicator

This bit will be low for the first transmitted word. If a button is held down for more than one transmitted code word, this bit will be set to indicate a repeated code word and remain set until the button is released (Figure 8-4).

## 5.8 $\overline{\text{LED}}$ Output Operation

During normal transmission the  $\overline{\text{LED}}$  output is LOW. If the supply voltage drops below the low voltage trip point, the  $\overline{\text{LED}}$  output will be toggled at approximately 5Hz during the transmission (Section 3.6.5).

## 6.0 PROGRAMMING THE HCS300

When using the HCS300 in a system, the user will have to program some parameters into the device including the serial number and the secret key before it can be used. The programming cycle allows the user to input all 192 bits in a serial data stream, which are then stored internally in EEPROM. Programming will be initiated by forcing the PWM line high, after the S3 line has been held high for the appropriate length of time line (Table 6-1 and Figure 6-1). After the program mode is entered, a delay must be provided to the device for the automatic bulk write cycle to complete. This will write all locations in the EEPROM to an all zeros pattern. The device can then be programmed by clocking in 16 bits at a time, using S3 as the clock line and PWM

as the data in line. After each 16-bit word is loaded, a programming delay is required for the internal program cycle to complete. This delay can take up to  $T_{wc}$ . At the end of the programming cycle, the device can be verified (Figure 6-2) by reading back the EEPROM. Reading is done by clocking the S3 line and reading the data bits on PWM. For security reasons, it is not possible to execute a verify function without first programming the EEPROM. **A verify operation can only be done once, immediately following the program cycle.**

**Note:** To ensure that the device does not accidentally enter programming mode, PWM should never be pulled high by the circuit connected to it. Special care should be taken when driving PNP RF transistors.

**FIGURE 6-1: PROGRAMMING WAVEFORMS**

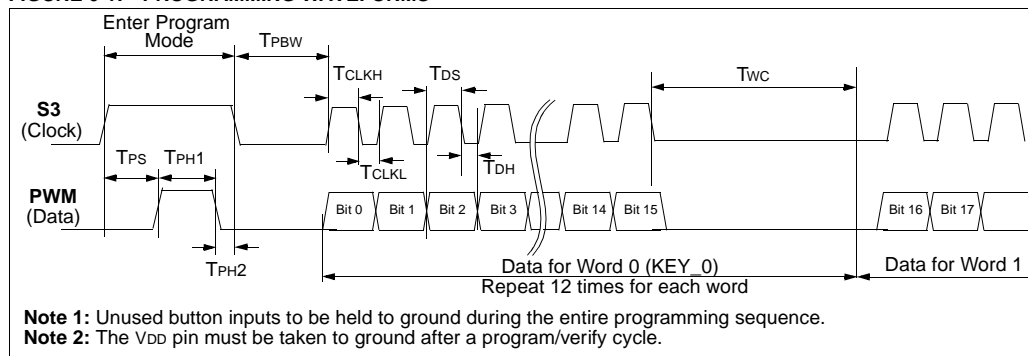

**FIGURE 6-2: VERIFY WAVEFORMS**

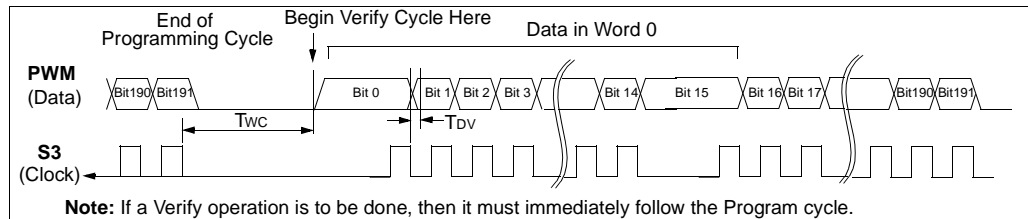

**TABLE 6-1: PROGRAMMING/VERIFY TIMING REQUIREMENTS**

V <sub>DD</sub> = 5.0V ± 10% 25° C ± 5 °C				
<b>Parameter</b>	<b>Symbol</b>	<b>Min.</b>	<b>Max.</b>	<b>Units</b>
Program mode setup time	T <sub>PS</sub>	3.5	4.5	ms
Hold time 1	T <sub>PH1</sub>	3.5	—	ms
Hold time 2	T <sub>PH2</sub>	50	—	μs
Bulk Write time	T <sub>PBW</sub>	—	2.2	ms
Program delay time	T <sub>PROG</sub>	—	2.2	ms
Program cycle time	T <sub>WC</sub>	—	36	ms
Clock low time	T <sub>CLKL</sub>	25	—	μs
Clock high time	T <sub>CLKH</sub>	25	—	μs
Data setup time	T <sub>DS</sub>	0	—	μs
Data hold time	T <sub>DH</sub>	18	—	μs
Data out valid time	T <sub>DV</sub>	10	24	μs

## 7.0 INTEGRATING THE HCS300 INTO A SYSTEM

Use of the HCS300 in a system requires a compatible decoder. This decoder is typically a microcontroller with compatible firmware. Microchip will provide (via a license agreement) firmware routines that accept transmissions from the HCS300 and decrypt the hopping code portion of the data stream. These routines provide system designers the means to develop their own decoding system.

### 7.1 Learning a Transmitter to a Receiver

In order for a transmitter to be used with a decoder, the transmitter must first be 'learned'. Several learning strategies can be followed in the decoder implementation. When a transmitter is learned to a decoder, it is suggested that the decoder stores the serial number and current synchronization value in EEPROM. The decoder must keep track of these values for every transmitter that is learned (Figure 7-1). The maximum number of transmitters that can be learned is only a function of how much EEPROM memory storage is available. The decoder must also store the manufacturer's code in order to learn a transmission transmitter, although this value will not change in a typical system so it is usually stored as part of the microcontroller ROM code. Storing the manufacturer's code as part of the ROM code is also better for security reasons.

It must be stated that some learning strategies have been patented and care must be taken not to infringe.

FIGURE 7-1: TYPICAL LEARN SEQUENCE

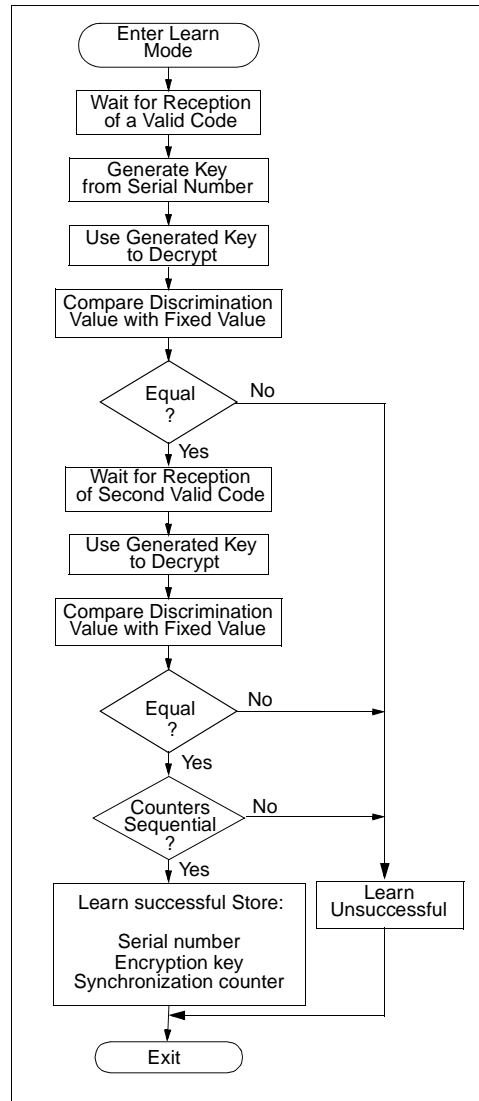

## 7.2 Decoder Operation

In a typical decoder operation (Figure 7-2), the key generation on the decoder side is done by taking the serial number from a transmission and combining that with the manufacturer's code to create the same secret key that was used by the transmitter. Once the secret key is obtained, the rest of the transmission can be decrypted. The decoder waits for a transmission and immediately can check the serial number to determine if it is a learned transmitter. If it is, it takes the encrypted portion of the transmission and decrypts it using the stored key. It uses the discrimination bits to determine if the decryption was valid. If everything up to this point is valid, the synchronization value is evaluated.

**FIGURE 7-2: TYPICAL DECODER OPERATION**

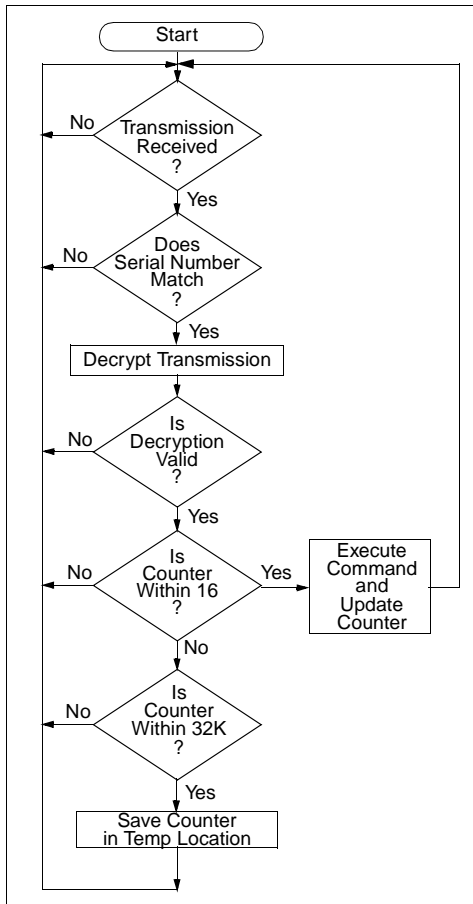

## 7.3 Synchronization with Decoder

The technology features a sophisticated synchronization technique (Figure 7-3) which does not require the calculation and storage of future codes. If the stored counter value for that particular transmitter and the counter value that was just decrypted are within a formatted window of say 16, the counter is stored and the command is executed. If the counter value was not within the single operation window, but is within the double operation window of say 32K window, the transmitted synchronization value is stored in temporary location and it goes back to waiting for another transmission. When the next valid transmission is received, it will check the new value with the one in temporary storage. If the two values are sequential, it is assumed that the counter had just gotten out of the single operation 'window', but is now back in sync, so the new synchronization value is stored and the command executed. If a transmitter has somehow gotten out of the double operation window, the transmitter will not work and must be re-learned. Since the entire window rotates after each valid transmission, codes that have been used are part of the 'blocked' (32K) codes and are no longer valid. This eliminates the possibility of grabbing a previous code and re-transmitting to gain entry.

**Note:** The synchronization method described in this section is only a typical implementation and because it is usually implemented in firmware, it can be altered to fit the needs of a particular system

**FIGURE 7-3: SYNCHRONIZATION WINDOW**

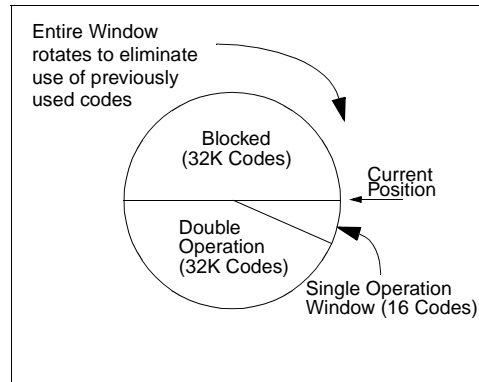



## 8.0 ELECTRICAL CHARACTERISTICS

**TABLE 8-1: ABSOLUTE MAXIMUM RATINGS**

Symbol	Item	Rating	Units
V <sub>DD</sub>	Supply voltage	-0.3 to 6.6	V
V <sub>IN</sub>	Input voltage	-0.3 to V <sub>DD</sub> + 0.3	V
V <sub>OUT</sub>	Output voltage	-0.3 to V <sub>DD</sub> + 0.3	V
I <sub>OUT</sub>	Max output current	50	mA
T <sub>STG</sub>	Storage temperature	-55 to +125	C (Note)
T <sub>LSOL</sub>	Lead soldering temp	300	C (Note)
V <sub>ESD</sub>	ESD rating	4000	V

**Note:** Stresses above those listed under “ABSOLUTE MAXIMUM RATINGS” may cause permanent damage to the device.

**TABLE 8-2: DC CHARACTERISTICS**

		2.0V < V <sub>DD</sub> < 3.0			3.0 < V <sub>DD</sub> < 6.3				
Parameter	Sym.	Min.	Typ. <sup>1</sup>	Max.	Min.	Typ. <sup>1</sup>	Max.	Unit	Conditions
Operating current (avg) <sup>2</sup>	I <sub>CC</sub>		0.2	1		1.0	2.5	mA mA	V <sub>DD</sub> = 3.0V V <sub>DD</sub> = 6.3V
Standby current	I <sub>CCS</sub>		0.1	1.0		0.1	1.0	μA	
Auto-shutoff current <sup>3,4</sup>	I <sub>CCS</sub>		40	75		160	650	μA	
High level Input voltage	V <sub>IH</sub>	0.55V <sub>DD</sub>		V <sub>DD</sub> +0.3	0.55V <sub>DD</sub>		V <sub>DD</sub> +0.3	V	
Low level input voltage	V <sub>IL</sub>	-0.3		0.15V <sub>DD</sub>	-0.3		0.15V <sub>DD</sub>	V	
High level output voltage	V <sub>OH</sub>	0.7V <sub>DD</sub>			0.7V <sub>DD</sub>			V V	I <sub>OH</sub> = -1.0 mA V <sub>DD</sub> = 2.0V I <sub>OH</sub> = -2.0 mA V <sub>DD</sub> = 6.3V
Low level output voltage	V <sub>OL</sub>			0.08V <sub>DD</sub>			0.08V <sub>DD</sub>	V V	I <sub>OL</sub> = 1.0 mA V <sub>DD</sub> = 2.0V I <sub>OL</sub> = 2.0 mA V <sub>DD</sub> = 6.3V
LED sink current <sup>5</sup>	I <sub>LED</sub>	1.0	1.8	2.5	2.0	2.7	3.7	mA mA	V <sub>LED</sub> <sup>6</sup> = 1.5V V <sub>DD</sub> = 3.0V V <sub>LED</sub> <sup>6</sup> = 1.5V V <sub>DD</sub> = 6.3V
Resistance; S0-S3	R <sub>SO-3</sub>	40	60	80	40	60	80	kΩ	V <sub>DD</sub> = 4.0V
Resistance; PWM	R <sub>PWM</sub>	80	120	160	80	120	160	kΩ	V <sub>DD</sub> = 4.0V

**Note 1:** Typical values are at 25°C.

**2:** No load.

**3:** Auto-shutoff current specification does not include the current through the input pulldown resistors.

**4:** Auto-shutoff current is periodically sampled and not 100% tested.

**5:** With V<sub>LOW Sel</sub> = 0 for operation from 2.0V to 3.0V and V<sub>LOW Sel</sub> = 1 for operation from 3.0V to 6.3V.

**6:** V<sub>LED</sub> is the voltage drop across the terminals of the LED.

**FIGURE 8-1: POWER UP AND TRANSMIT TIMING**

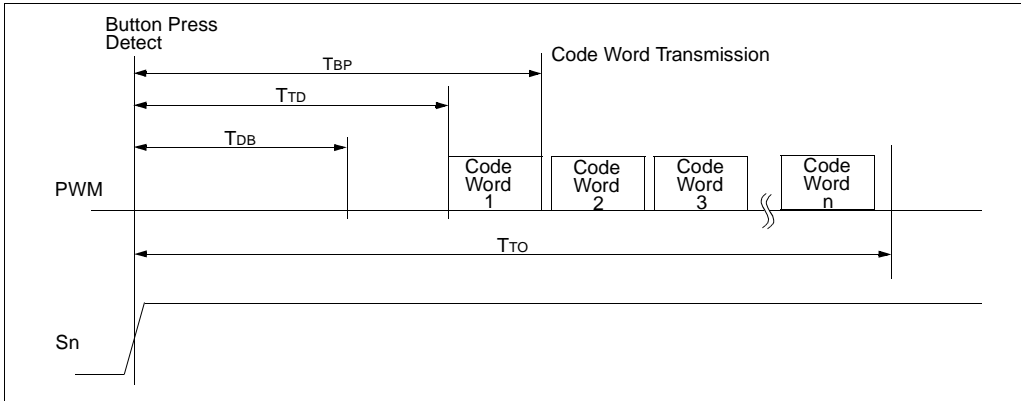

**TABLE 8-3: POWER UP AND TRANSMIT TIMING REQUIREMENTS**

VDD = +2.0 to 6.3V

Commercial (C): Tamb = 0°C to +70°C

Industrial (I): Tamb = -40°C to +85°C

Parameter	Symbol	Min.	Max.	Unit	Remarks
Time to second button press	TBP	10 + Code Word Time	26 + Code Word Time	ms	(Note 1)
Transmit delay from button detect	TTD	10	26	ms	
Debounce delay	TDB	6	13	ms	
Auto-shutoff time-out period	TTO	20	35	s	(Note 2)

**Note 1:** TBP is the time in which a second button can be pressed without completion of the first code word and the intention was to press the combination of buttons.

**2:** The auto shutoff timeout period is not tested.

**FIGURE 8-2: PWM FORMAT**

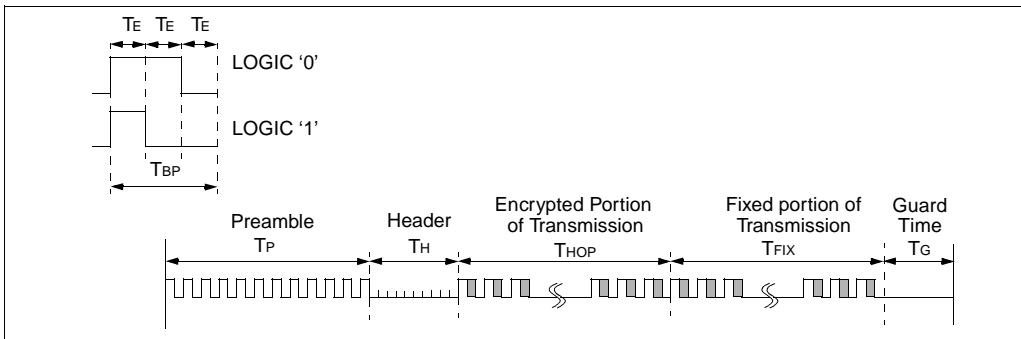

**FIGURE 8-3: PREAMBLE/HEADER FORMAT**

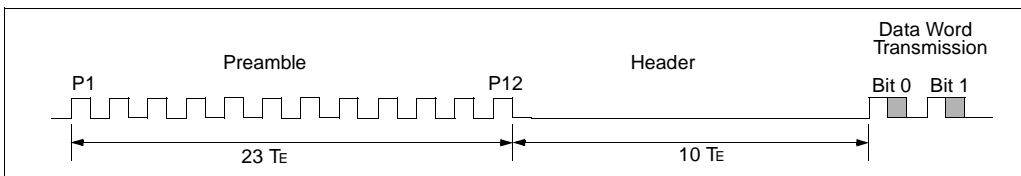

**FIGURE 8-4: DATA WORD FORMAT**

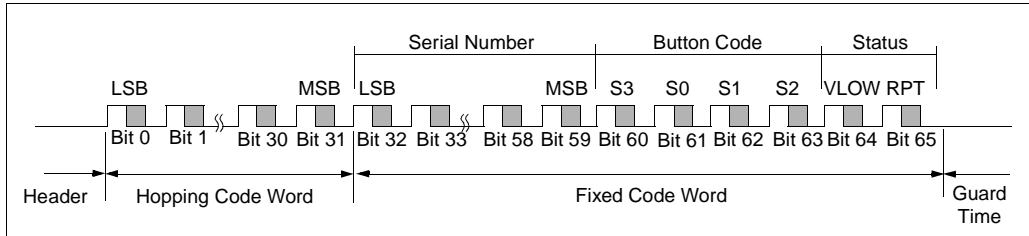
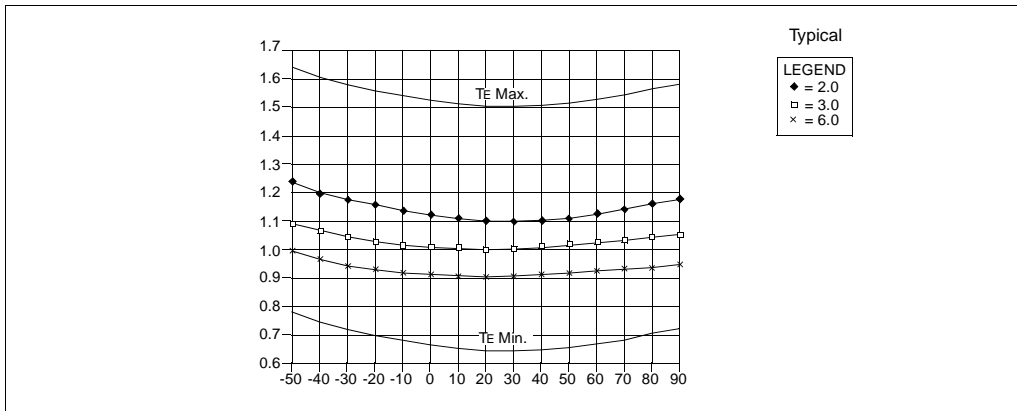

**TABLE 8-4: CODE WORD TRANSMISSION TIMING REQUIREMENTS**

V <sub>DD</sub> = +2.0 to 6.0V Commercial(C):T <sub>amb</sub> = 0°C to +70°C Industrial(I):T <sub>amb</sub> = -40°C to +85°C			Code Words Transmitted									Units
Symbol	Characteristic	Number of TE	All			1 out of 2			1 out of 4			
			Min.	Typ.	Max.	Min.	Typ.	Max.	Min.	Typ.	Max.	
T <sub>E</sub>	Basic pulse element	1	260	400	660	130	200	330	65	100	165	μs
T <sub>BP</sub>	PWM bit pulse width	3	780	1200	1980	390	600	990	195	300	495	μs
T <sub>P</sub>	Preamble duration	23	6.0	9.2	15.2	3.0	4.6	7.6	1.5	2.3	3.8	ms
T <sub>H</sub>	Header duration	10	2.6	4.0	6.6	1.3	2.0	3.3	0.7	1.0	1.7	ms
T <sub>HOP</sub>	Hopping code duration	96	25.0	38.4	63.4	12.5	19.2	31.7	6.2	9.6	15.8	ms
T <sub>FIX</sub>	Fixed code duration	102	26.5	40.8	67.3	13.3	20.4	33.7	6.6	10.2	16.8	ms
T <sub>G</sub>	Guard Time	39	10.1	15.6	25.7	5.1	7.8	12.9	2.5	3.9	6.4	ms
—	Total Transmit Time	270	70.2	108.0	178.2	35.1	54.0	89.1	17.6	27.0	44.6	ms
—	PWM data rate	—	1282	833	505	2564	1667	1010	5128	3333	2020	bps

**Note:** The timing parameters are not tested but derived from the oscillator clock.

**FIGURE 8-5: HCS300 TE VS. TEMP**



# HCS300

## HCS300 PRODUCT IDENTIFICATION SYSTEM

To order or obtain information, e.g., on pricing or delivery, refer to the factory or the listed sales office.

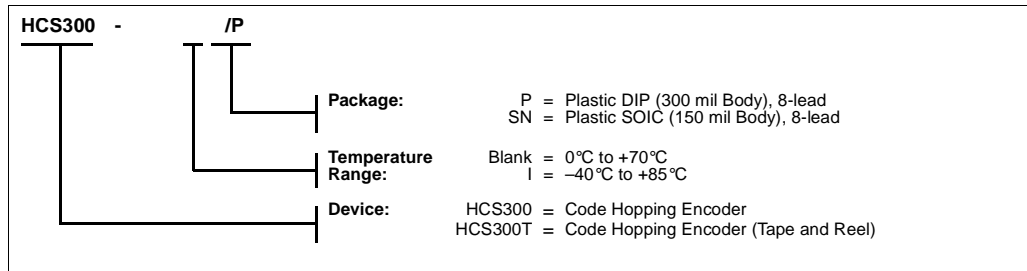

### Sales and Support

#### Data Sheets

Products supported by a preliminary Data Sheet may have an errata sheet describing minor operational differences and recommended workarounds. To determine if an errata sheet exists for a particular device, please contact one of the following:

1. Your local Microchip sales office
2. The Microchip Corporate Literature Center U.S. FAX: (480) 786-7277.
3. The Microchip Worldwide Site ([www.microchip.com](http://www.microchip.com))

Please specify which device, revision of silicon and Data Sheet (include Literature #) you are using.

#### New Customer Notification System

Register on our web site ([www.microchip.com/cn](http://www.microchip.com/cn)) to receive the most current information on our products.

**NOTES:**

NOTES:

**NOTES:**



## WORLDWIDE SALES AND SERVICE

### AMERICAS

#### Corporate Office

Microchip Technology Inc.  
2355 West Chandler Blvd.  
Chandler, AZ 85224-6199  
Tel: 480-786-7200 Fax: 480-786-7277  
Technical Support: 480-786-7627  
Web Address: <http://www.microchip.com>

#### Atlanta

Microchip Technology Inc.  
500 Sugar Mill Road, Suite 200B  
Atlanta, GA 30350  
Tel: 770-640-0034 Fax: 770-640-0307

#### Boston

Microchip Technology Inc.  
5 Mount Royal Avenue  
Marlborough, MA 01752  
Tel: 508-480-9990 Fax: 508-480-8575

#### Chicago

Microchip Technology Inc.  
333 Pierce Road, Suite 180  
Itasca, IL 60143  
Tel: 630-285-0071 Fax: 630-285-0075

#### Dallas

Microchip Technology Inc.  
4570 Westgrove Drive, Suite 160  
Addison, TX 75248  
Tel: 972-818-7423 Fax: 972-818-2924

#### Dayton

Microchip Technology Inc.  
Two Prestige Place, Suite 150  
Miamisburg, OH 45342  
Tel: 937-291-1654 Fax: 937-291-9175

#### Detroit

Microchip Technology Inc.  
Tri-Atria Office Building  
32255 Northwestern Highway, Suite 190  
Farmington Hills, MI 48334  
Tel: 248-538-2250 Fax: 248-538-2260

#### Los Angeles

Microchip Technology Inc.  
18201 Von Karman, Suite 1090  
Irvine, CA 92612  
Tel: 949-263-1888 Fax: 949-263-1338

#### New York

Microchip Technology Inc.  
150 Motor Parkway, Suite 202  
Hauppauge, NY 11788  
Tel: 631-273-5305 Fax: 631-273-5335

#### San Jose

Microchip Technology Inc.  
2107 North First Street, Suite 590  
San Jose, CA 95131  
Tel: 408-436-7950 Fax: 408-436-7955

### AMERICAS (continued)

#### Toronto

Microchip Technology Inc.  
5925 Airport Road, Suite 200  
Mississauga, Ontario L4V 1W1, Canada  
Tel: 905-405-6279 Fax: 905-405-6253

### ASIA/PACIFIC

#### Hong Kong

Microchip Asia Pacific  
Unit 2101, Tower 2  
Metroplaza  
223 Hing Fong Road  
Kwai Fong, N.T., Hong Kong  
Tel: 852-2-401-1200 Fax: 852-2-401-3431

#### Beijing

Microchip Technology, Beijing  
Unit 915, 6 Chaoyangmen Bei Dajie  
Dong Erhuan Road, Dongcheng District  
New China Hong Kong Manhattan Building  
Beijing 100027 PRC  
Tel: 86-10-85282100 Fax: 86-10-85282104

#### India

Microchip Technology Inc.  
India Liaison Office  
No. 6, Legacy, Convent Road  
Bangalore 560 025, India  
Tel: 91-80-229-0061 Fax: 91-80-229-0062

#### Japan

Microchip Technology Intl. Inc.  
Benex S-1 6F  
3-18-20, Shinyokohama  
Kohoku-Ku, Yokohama-shi  
Kanagawa 222-0033 Japan  
Tel: 81-45-471-6166 Fax: 81-45-471-6122

#### Korea

Microchip Technology Korea  
168-1, Youngbo Bldg. 3 Floor  
Samsung-Dong, Kangnam-Ku  
Seoul, Korea  
Tel: 82-2-554-7200 Fax: 82-2-558-5934

#### Shanghai

Microchip Technology  
RM 406 Shanghai Golden Bridge Bldg.  
2077 Yan'an Road West, Hong Qiao District  
Shanghai, PRC 200335  
Tel: 86-21-6275-5700 Fax: 86 21-6275-5060

### ASIA/PACIFIC (continued)

#### Singapore

Microchip Technology Singapore Pte Ltd.  
200 Middle Road  
#07-02 Prime Centre  
Singapore 188980  
Tel: 65-334-8870 Fax: 65-334-8850

#### Taiwan, R.O.C

Microchip Technology Taiwan  
10F-1C 207  
Tung Hua North Road  
Taipei, Taiwan, ROC  
Tel: 886-2-2717-7175 Fax: 886-2-2545-0139

### EUROPE

#### United Kingdom

Arizona Microchip Technology Ltd.  
505 Eskdale Road  
Wokingham  
Berkshire, England RG41 5TU  
Tel: 44 118 921 5858 Fax: 44-118 921-5835

#### Denmark

Microchip Technology Denmark ApS  
Regus Business Centre  
Lautrup hof 1-3  
Ballerup DK-2750 Denmark  
Tel: 45 4420 9895 Fax: 45 4420 9910

#### France

Arizona Microchip Technology SARL  
Parc d'Activite du Moulin de Massy  
43 Rue du Saule Trapu  
Batiment A - 1er Etage  
91300 Massy, France  
Tel: 33-1-69-53-63-20 Fax: 33-1-69-30-90-79

#### Germany

Arizona Microchip Technology GmbH  
Gustav-Heinemann-Ring 125  
D-81739 München, Germany  
Tel: 49-89-627-144 0 Fax: 49-89-627-144-44

#### Italy

Arizona Microchip Technology SRL  
Centro Direzionale Colleoni  
Palazzo Taurus 1 V. Le Colleoni 1  
20041 Agrate Brianza  
Milan, Italy  
Tel: 39-039-65791-1 Fax: 39-039-6899883

11/15/99

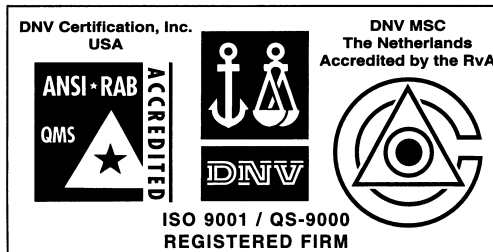

Microchip received QS-9000 quality system certification for its worldwide headquarters, design and water fabrication facilities in Chandler and Tempe, Arizona in July 1999. The Company's quality system processes and procedures are QS-9000 compliant for its PICmicro® 8-bit MCUs, KEELOC® code hopping devices, Serial EEPROMs and microperipheral products. In addition, Microchip's quality system for the design and manufacture of development systems is ISO 9001 certified.

All rights reserved. © 1999 Microchip Technology Incorporated. Printed in the USA. 11/99 Printed on recycled paper.

Information contained in this publication regarding device applications and the like is intended for suggestion only and may be superseded by updates. No representation or warranty is given and no liability is assumed by Microchip Technology Incorporated with respect to the accuracy or use of such information, or infringement of patents or other intellectual property rights arising from such use or otherwise. Use of Microchip's products as critical components in life support systems is not authorized except with express written approval by Microchip. No licenses are conveyed, implicitly or otherwise, under any intellectual property rights. The Microchip logo and name are registered trademarks of Microchip Technology Inc. in the U.S.A. and other countries. All rights reserved. All other trademarks mentioned herein are the property of their respective companies.